



Product/Process
Change
Notification
PCN08044

| | | | | |
|-------------------------|---------|--|--------------------------------|-------------------|
| Product: | PCle | | Part Numbers Concerned: | See attached list |
| Product Manager: | Alan Lo | | Issue Date: | March 28, 2008 |
| | | | Page(s): | 1/3 |
| Distribution: | GLOBAL | | | |

Subject

Product Design Change

Nature of Change:

Since the global raw materials are rising up rapidly, FCI decided to implement product design change to improve the manufacture process, and increase the efficiency to secure our service and maintain long term relationship with customers.

Removing the metal clip from the post

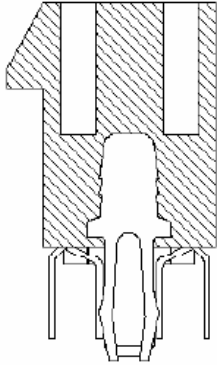

W/ CLIP
CHANGE BEFORE

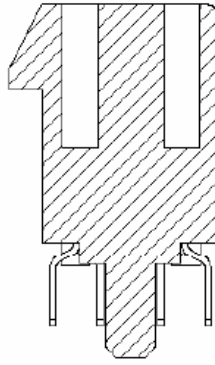

WO/ CLIP
CHANGE AFTER

Dimension and Apparel changes

| Location# | Before | After |
|-----------|---------------|----------------|
| 1 | 1.7 \pm 0.1 | 1.78 \pm 0.1 |
| 2 | 13.75 | 13.55 |
| 3 | 0.8 \pm 0.1 | 1.0 \pm 0.1 |

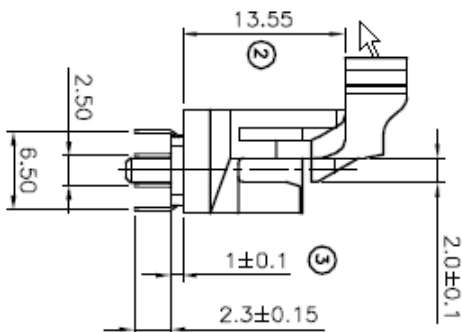
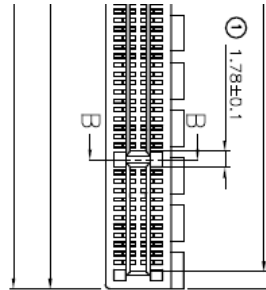

| | | |
|---|-----------------|-----------------|
| 4 | 17.8 \pm 0.25 | 17.6 \pm 0.25 |
| 5 | 12.85 | 12.65 |
| 6 | 10.95 | 10.75 |

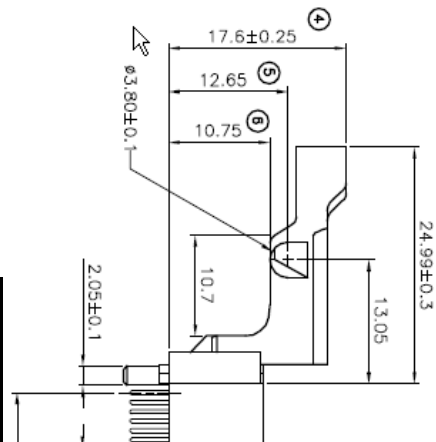

| | | |
|----|----------------|----------------|
| 7 | 7.2 \pm 0.1 | 7.4 \pm 0.1 |
| 8 | 1.85 \pm 0.1 | 1.77 \pm 0.1 |
| 9 | 0.8 \pm 0.1 | 0.95 \pm 0.1 |
| 10 | 10.2 \pm 0.1 | 10.0 \pm 0.1 |
| 11 | 4.4 \pm 0.1 | 4.3 \pm 0.1 |
| 12 | Areva | FCI |

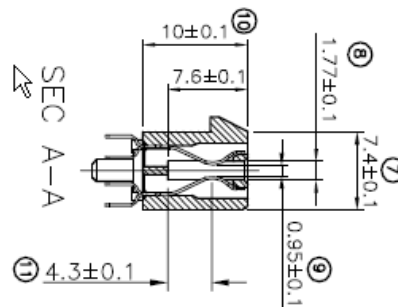

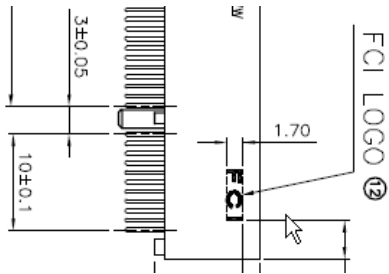

Implementation Date: June 28, 2008

Affected Part Numbers & Alternative Products:

| Current Part no | Alternative / Replacement part no |
|-------------------|-----------------------------------|
| 10046742-xxxxxTLF | 10083987-xxxxxTLF |
| 10074375-xxxxxTLF | 10085429-xxxxxTLF |

Action Required:

- Sales team needs to inform customers for this notification.

For questions regarding this PCN contact:

- Additional inquires can be directed to Alan Lo, Product Manager.

For questions regarding this PCN contact:

Alan Lo
 Tel: 886-3-4549720
 Fax: 886-3-4515897
 Email: alan.lo@fci.com